

REVISIONS			
REV	DESCRIPTION	DATE	APPROVED
A1	REVISED PER ECO-11-005294	14APR11	HMR

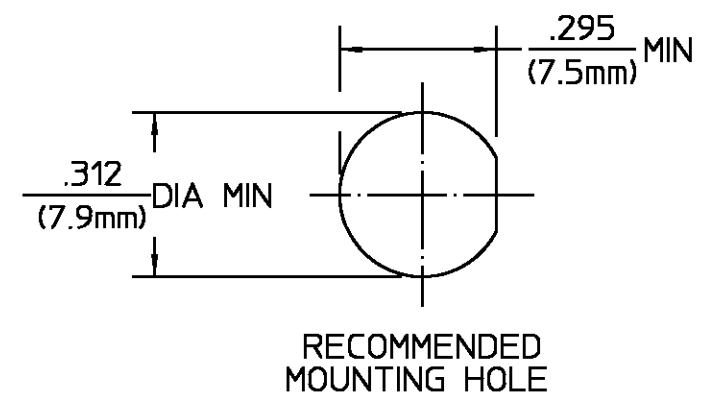
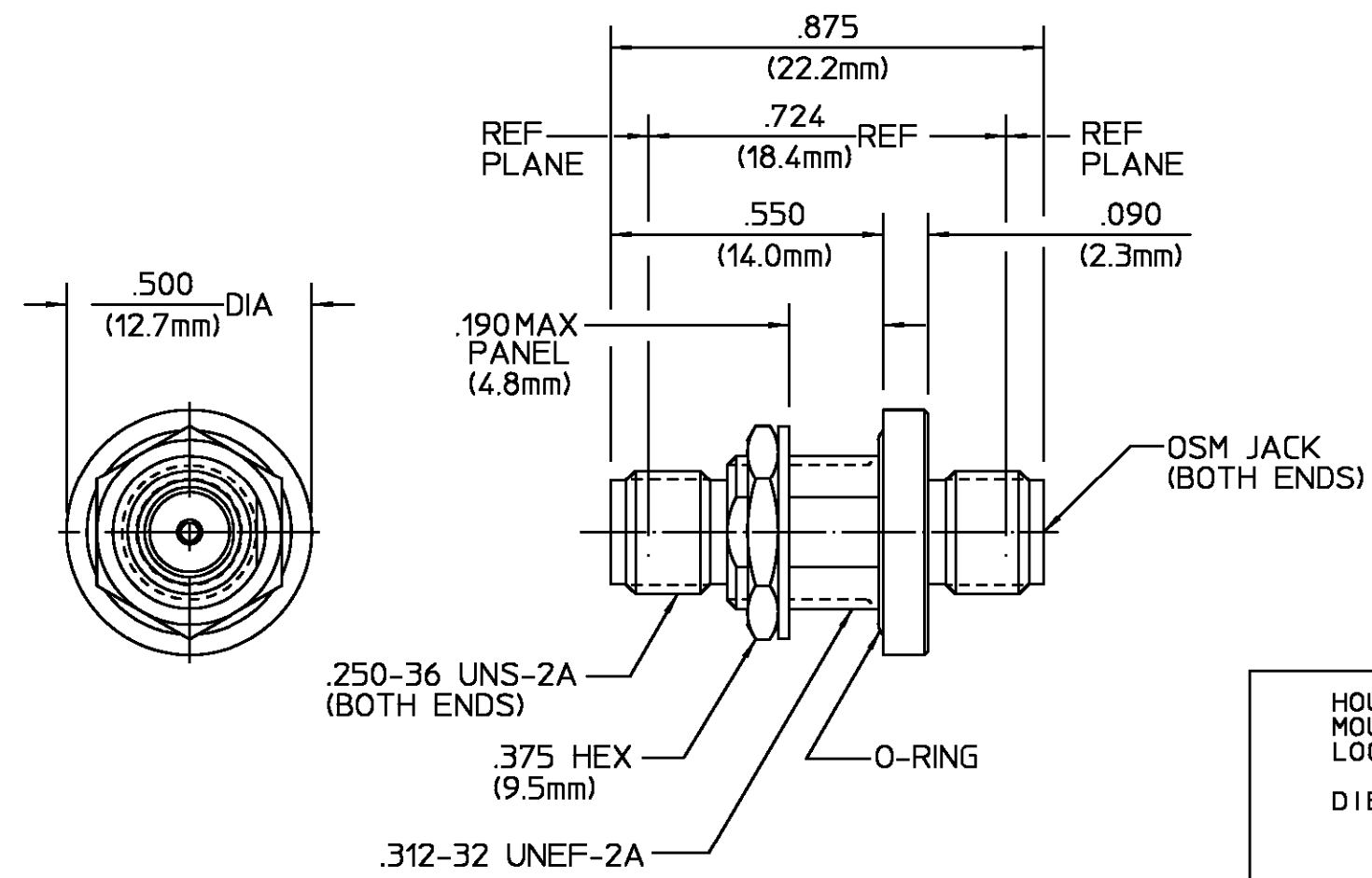

HOUSING MOUNTING NUT LOCKWASHER	STAINLESS STEEL PER ASTM-A484 AND ASTM-A582, TYPE 303	GOLD PLATE PER MIL-G-45204 OVER NICKEL PLATE PER QQ-N-290
DIELECTRIC	TFE FLUOROCARBON PER MIL-P-19468 AND FED SPEC L-P-403	N/A
CENTER CONTACT	BERYLLIUM COPPER PER QQ-C-530, ALLOY 173	GOLD PLATE PER MIL-G-45204 OVER COPPER PLATE PER MIL-C-14550
CONTACT EXT.	IRON-NICKEL ALLOY PER MIL-I-23011 CLASS 2	GOLD PLATE PER MIL-G-45204 OVER NICKEL PLATE PER QQ-N-290
O-RING	EPM PER ASTM-D2000-70	N/A
HERMETIC SEAL	GLASS BEAD	N/A

ELECTRICAL	MECHANICAL	ENVIRONMENTAL
Nominal Impedance (Ohms) <u>50</u>	Interface Dimensions MIL-STD-348A, Fig. 310.2	Temperature Rating <u>-65°C to +165°C</u>
Frequency Range (GHz) <u>DC to 18.0</u>	Recommended Mating Torque <u>7 to 10 In-Lbs</u>	Vibration MIL-STD-202, Method 204, Condition D
Volt Rating (VRMS MAX) @ Sea Level <u>335</u>	Mating Characteristics:	Shock MIL-STD-202, Method 213, Condition I
VSWR <u>1.10 + .010 f(GHz)</u>	Insertion (MAX Lbs) <u>3.0</u>	Thermal Shock MIL-STD-202, Method 107, Condition C
Insertion Loss (dB MAX) <u>.15√f(GHz)</u>	Withdrawal (MIN Oz) <u>1.0</u>	Moisture Resistance MIL-STD-202, Method 106
RF Leakage (dB MIN) <u>-90</u>	Force to Engage and Disengage (In-Lbs MAX) <u>2.0</u>	Corrosion - MIL-STD-202, Method 101, Condition B, 5% salt spray
Corona, 70,000 Ft (VRMS MIN) <u>250</u>	Center Contact Captivation	
Dielectric Withstanding Voltage (VRMS MIN) @ Sea Level <u>1000</u>	Axial (Lbs) <u>6.0</u>	
Contact Resistance (Milliohms MAX)	Radial (In-Oz) <u>N/A</u>	
Center Contact <u>12.0</u>	Seal:	
Outer Contact <u>4.0</u>	Hermetic: <u>1 x 10⁻⁷ cc/sec</u>	
RF High Potential @ Sea Level (VRMS MIN @ 5 MHz) <u>670</u>	Weatherproof: <u>30 psi MAX</u>	
I.R.(Megohms MIN) <u>5000</u>	Mounting Seal	
	Weight (Grams)	

COMPONENT	MATERIAL	FINISH
UNLESS OTHERWISE SPECIFIED DIMENSIONS ARE IN INCHES TOLERANCE ON		
FRAC.	DEC.	ANGLES
± 1/64	± .005	± 1°
DRAWN BY <u>B.W.C.</u> DATE <u>6-9-67</u>		
CHECKED BY <u>C.S.D.</u> DATE <u>1-14-68</u>		
APP'D BY <u>D.NANIA</u> DATE <u>1-15-68</u>		
USE ASSY PROCEDURE		TITLE <u>OSM BULKHEAD FEEDTHRU JACK TO JACK ADAPTER-HERMETIC SEAL</u>
NO. AP <u>N/A</u>		SIZE <u>B</u> CODE IDENT NO. <u>26805</u> 1054874-1 REV <u>A1</u>
CUSTOMER DRAWING		SCALE <u>3:1</u> SHEET <u>1 OF 1</u>