

D00 NOT SCALE

DELPHI PACKARD ELECTRIC SYSTEMS

REVISED 0110 1486

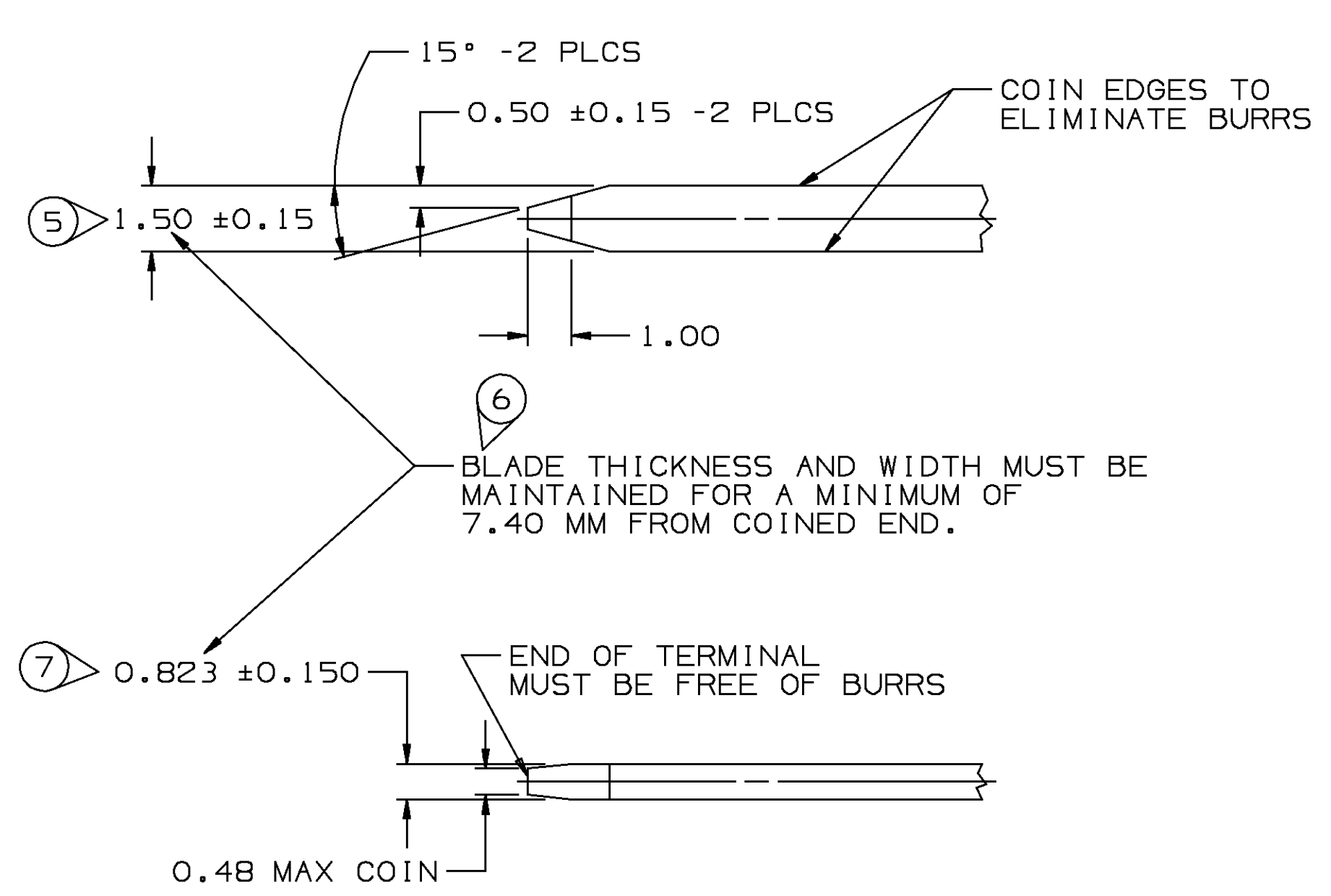

BLADE THICKNESS AND WIDTH MUST BE MAINTAINED FOR A MINIMUM OF 7.40 MM FROM COINED END.

MATERIAL SPECIFICATIONS

RECOMMENDED
 BASE METAL - CDA-210, EXTRA SPRING TEMPER
 PLATING - 0.0050±0.0025 MM THICK TIN

MINIMUMS
 ELECTRICAL CONDUCTIVITY - ≥20% IACS AT 20°C. USE OF A MATERIAL WITH CONDUCTIVITY < 20% IACS MUST BE APPROVED BY PACKARD ELECTRIC MATERIALS ENGINEERING.
 TENSILE STRENGTH - 407 MPa
 PLATING - FOR LOW ENERGY (≤5v) AND NON-PASSENGER COMPARTMENT POWER CIRCUITS, 0.0050±0.0025 MM THICK TIN. FOR MATERIALS CONTAINING 10% OR MORE ZINC, AN UNDERPLATE OF COPPER 0.0050±0.0025 MM THICK IS REQUIRED.

MATING BLADE INFORMATION
 SCALE B:1

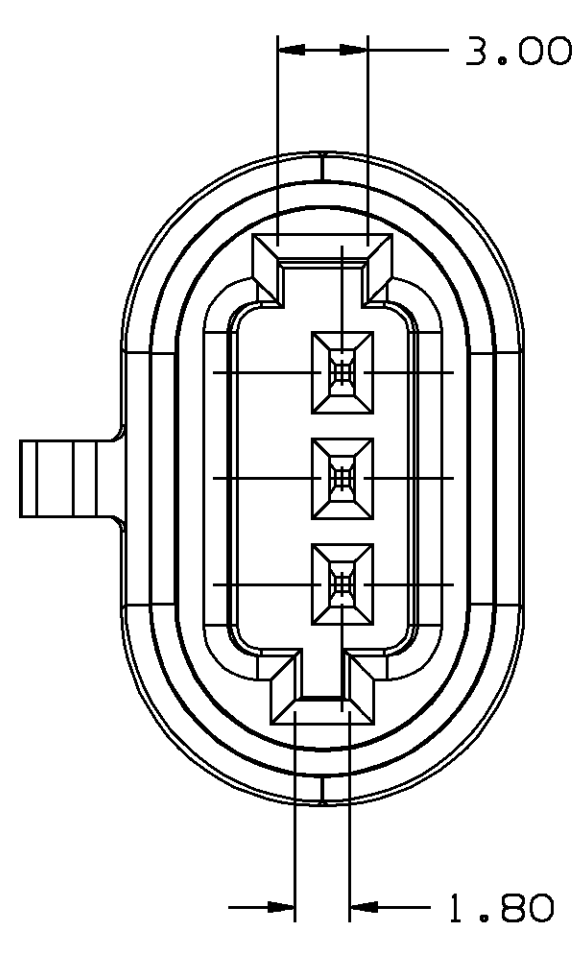

TYPE 102
 SAME AS TYPE 101 EXCEPT AS SHOWN

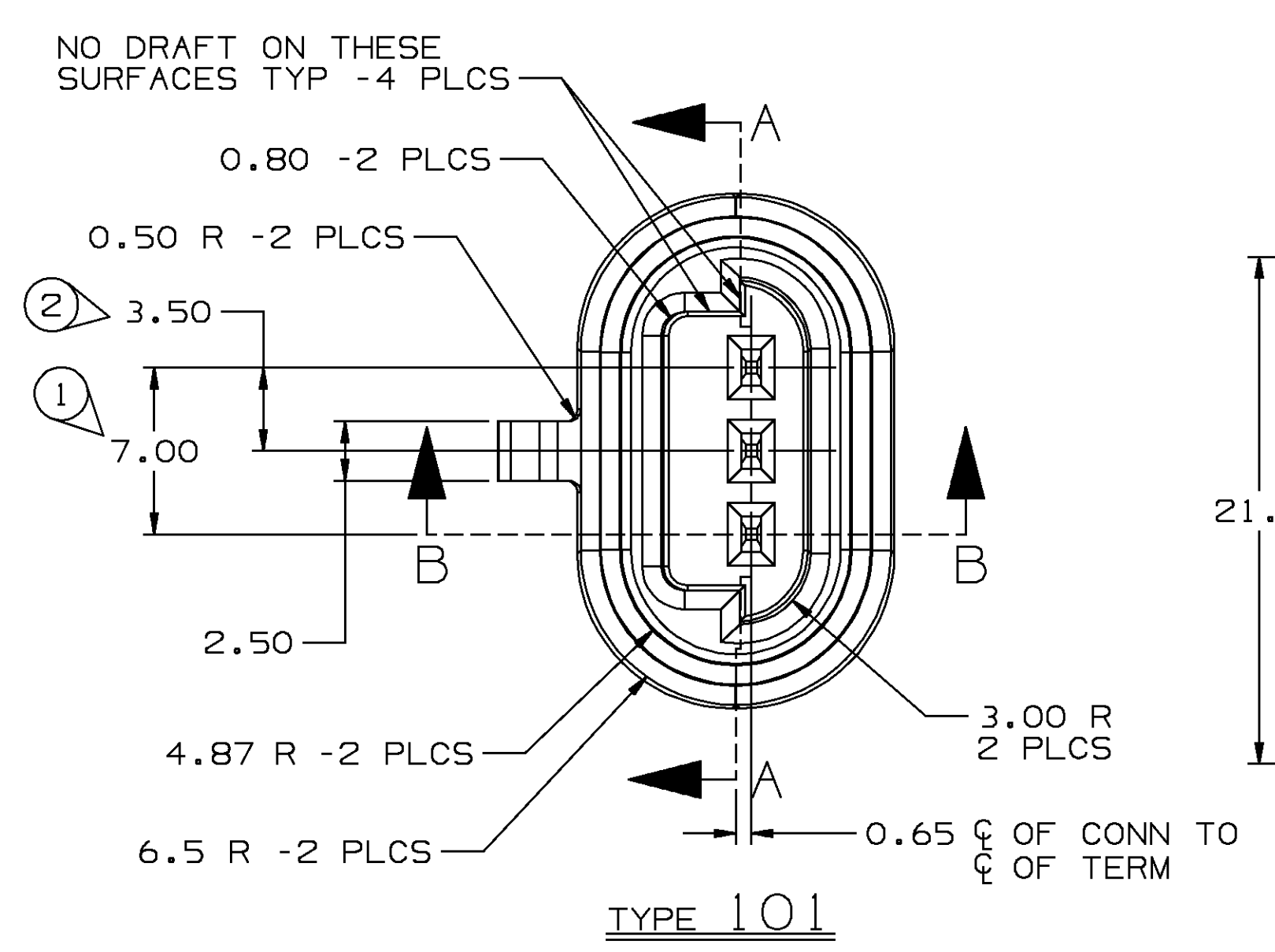

TYPE 101

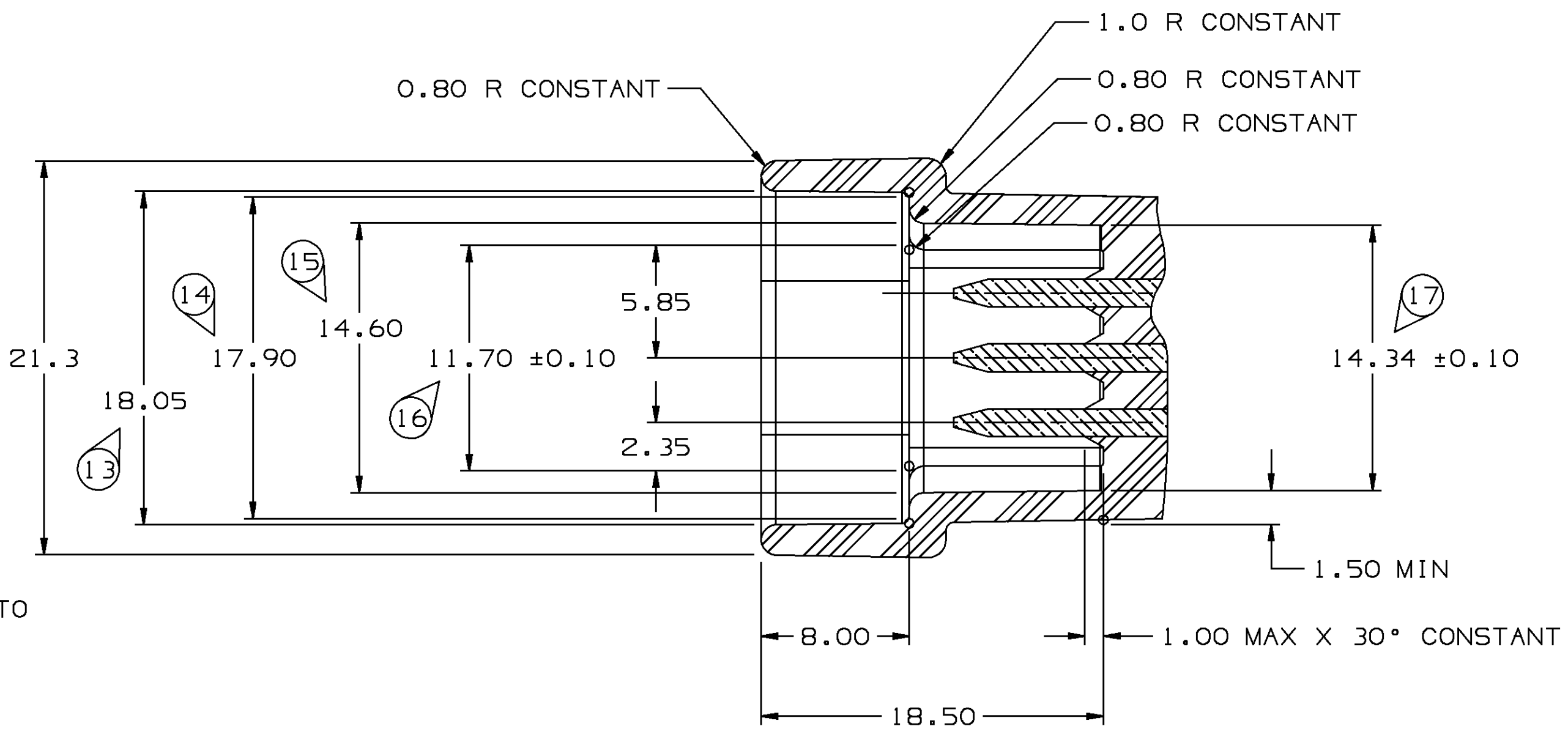

SECTION A-A

- NOTES:
- UNLESS OTHERWISE SPECIFIED AND/OR INDICATED: DIMENSIONS ARE TO FACE OF VIEW SHOWN AND AUTOMATICALLY ROUNDED BY COMPUTER FOR INSPECTION. (SEE MATH MODEL FOR PRECISE DIMENSION) FOR ALL OTHER DIMENSIONS NOT SHOWN BUT REQUIRED FOR TOOL BUILD, SEE MATH MODEL FOR PRECISE TOOL PATH DATA. ALL RADII 0.40 DRAFT 15 1° ON ALL OUTSIDE SURFACES
 - RECOMMENDED MATERIAL: GLASS REINFORCED NYLON OR POLYESTER

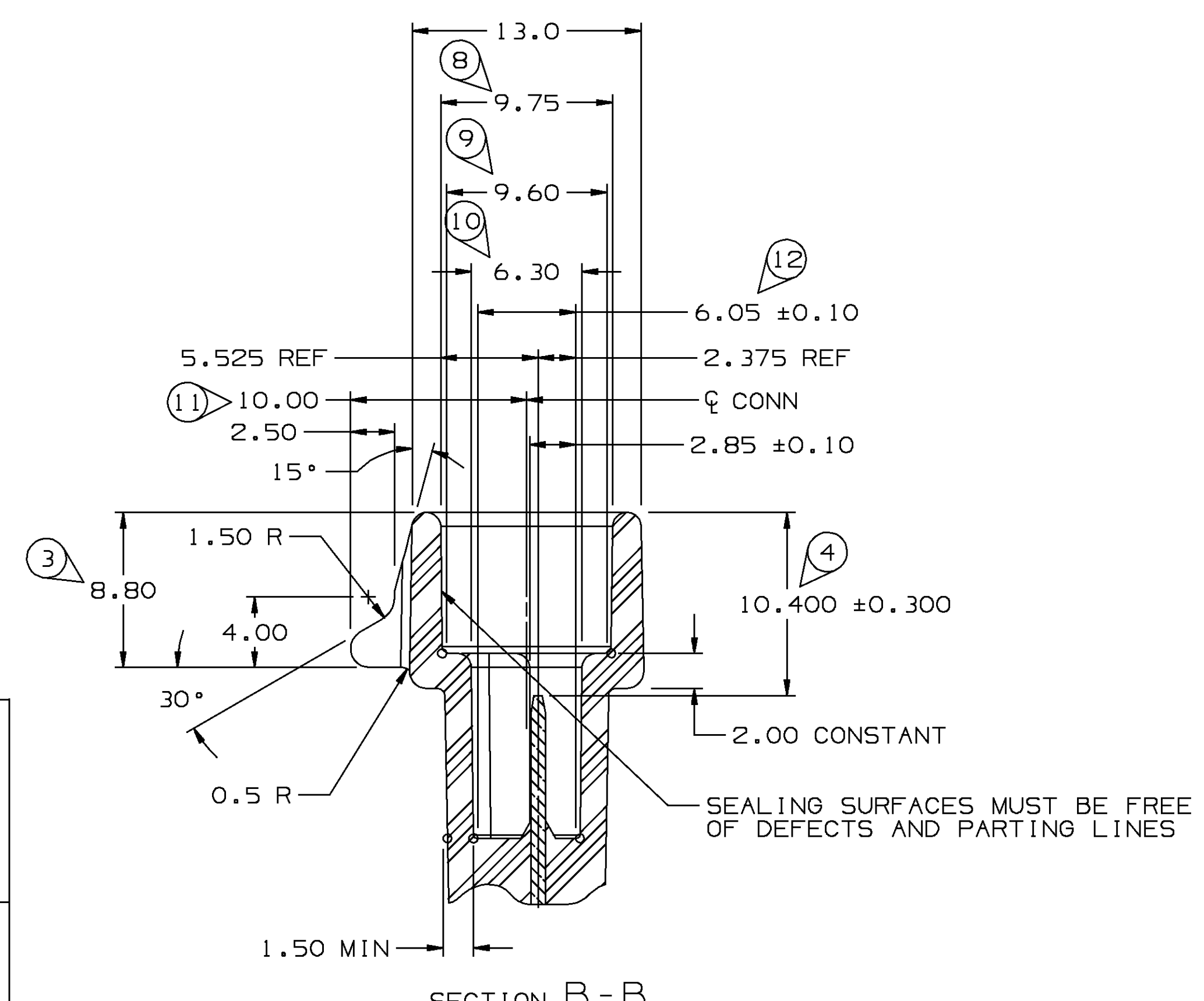

SECTION B-B

MATING CONNECTOR INFORMATION

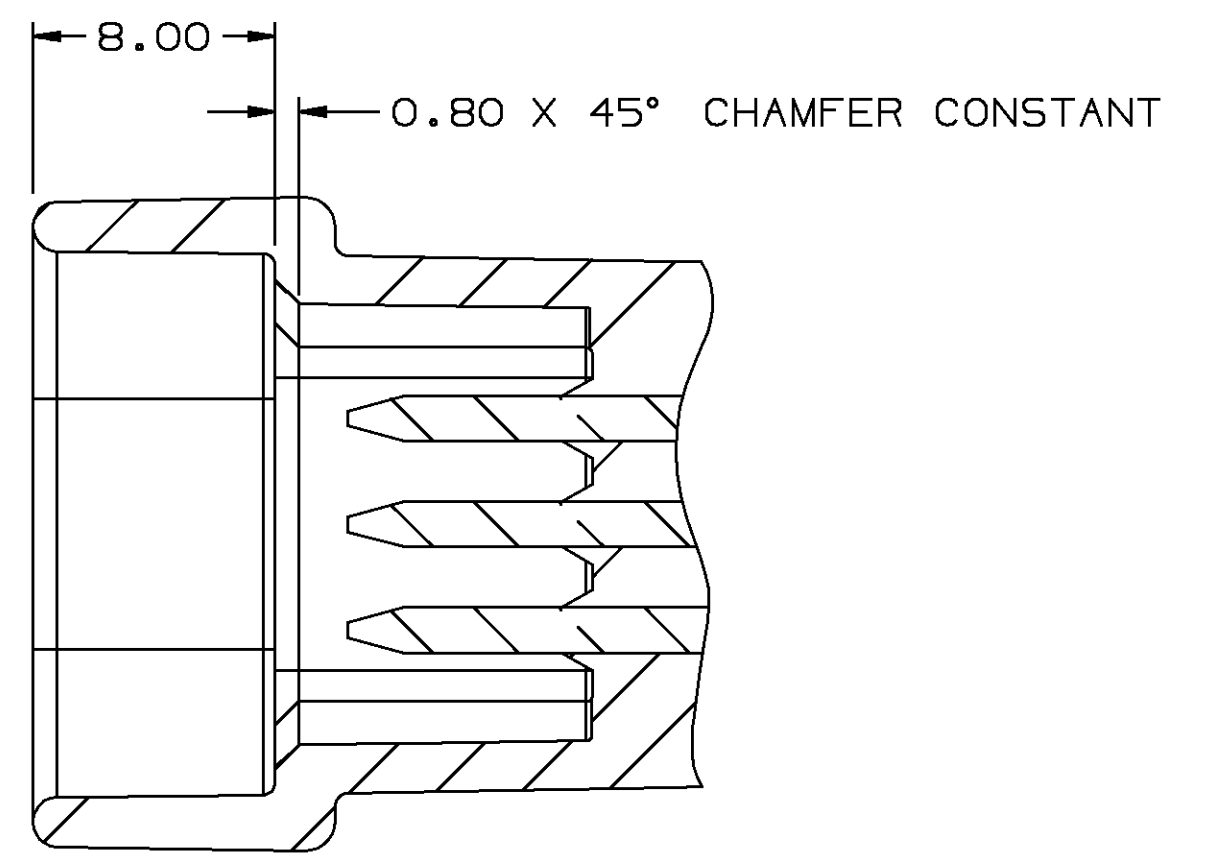
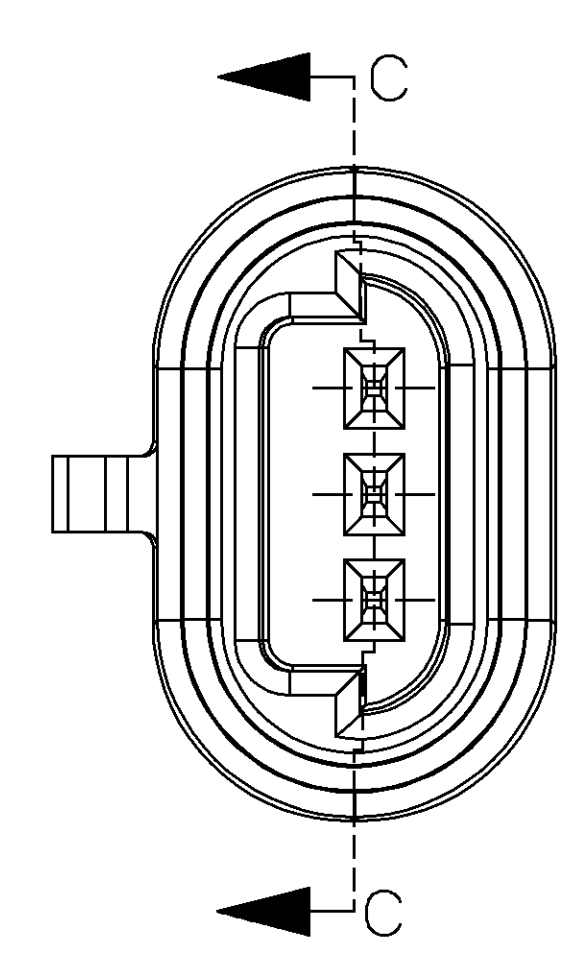

SECTION C-C

OPTIONAL MATING CONNECTOR INFORMATION
 SAME AS ORIGINAL CONSTRUCTION EXCEPT AS SHOWN

PART NO
1216 2266

GENERAL NOTE
 "C" DENOTES DIMENSIONS AND CHARACTERISTICS THAT ARE IMPORTANT TO THE FUNCTION AND/OR PROCESSING OF THE PART THAT HAVE SPECIAL ACCEPTANCE CRITERIA FOR PRODUCTION APPROVAL. THIS DRAWING HAS 17 SNOWCONES.

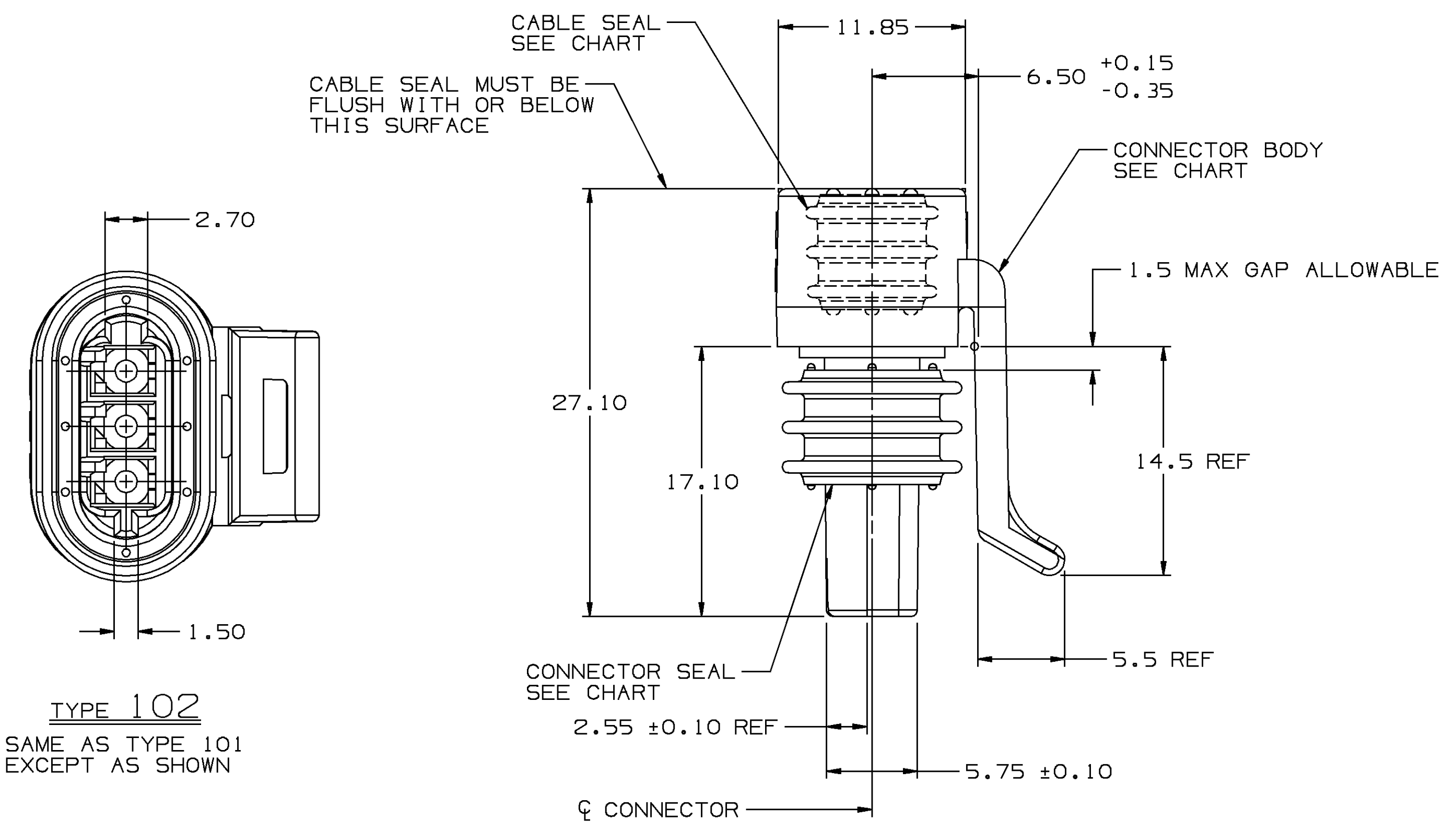

TYPE 102
 SAME AS TYPE 101 EXCEPT AS SHOWN

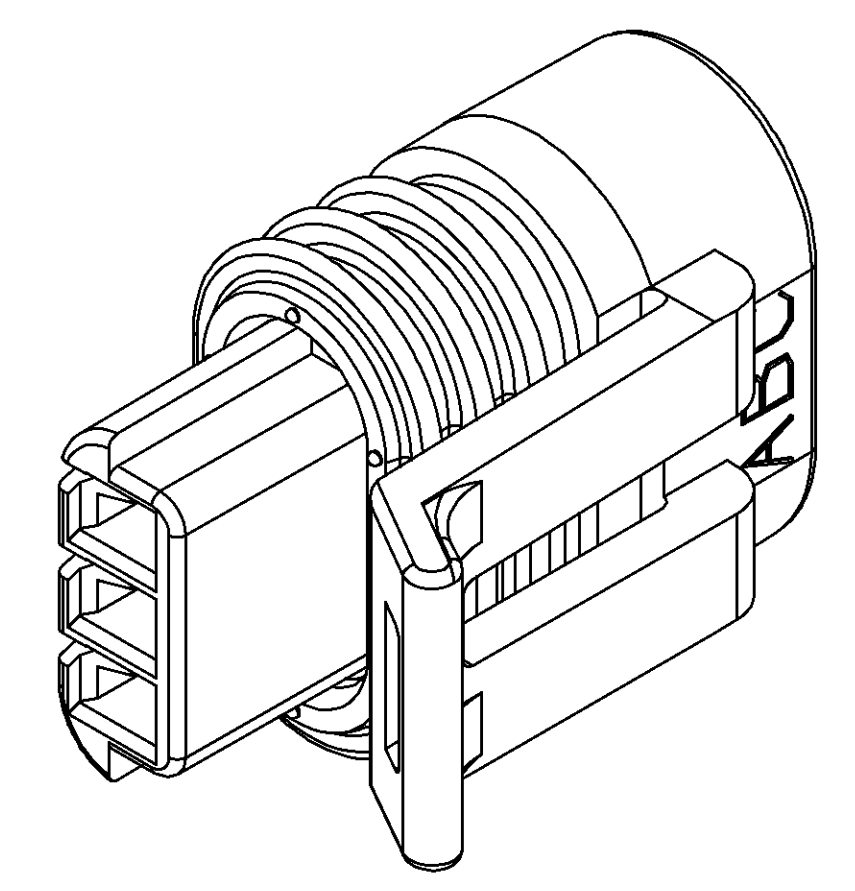

TYPE 101

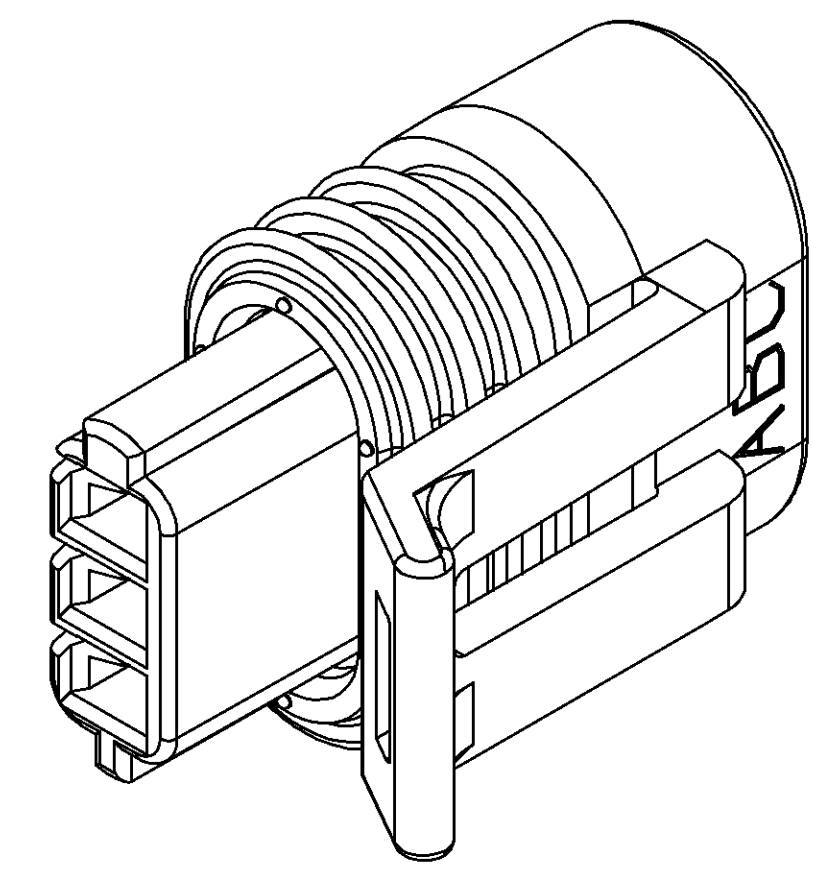

TYPE 102
 SAME AS TYPE 101 EXCEPT AS SHOWN

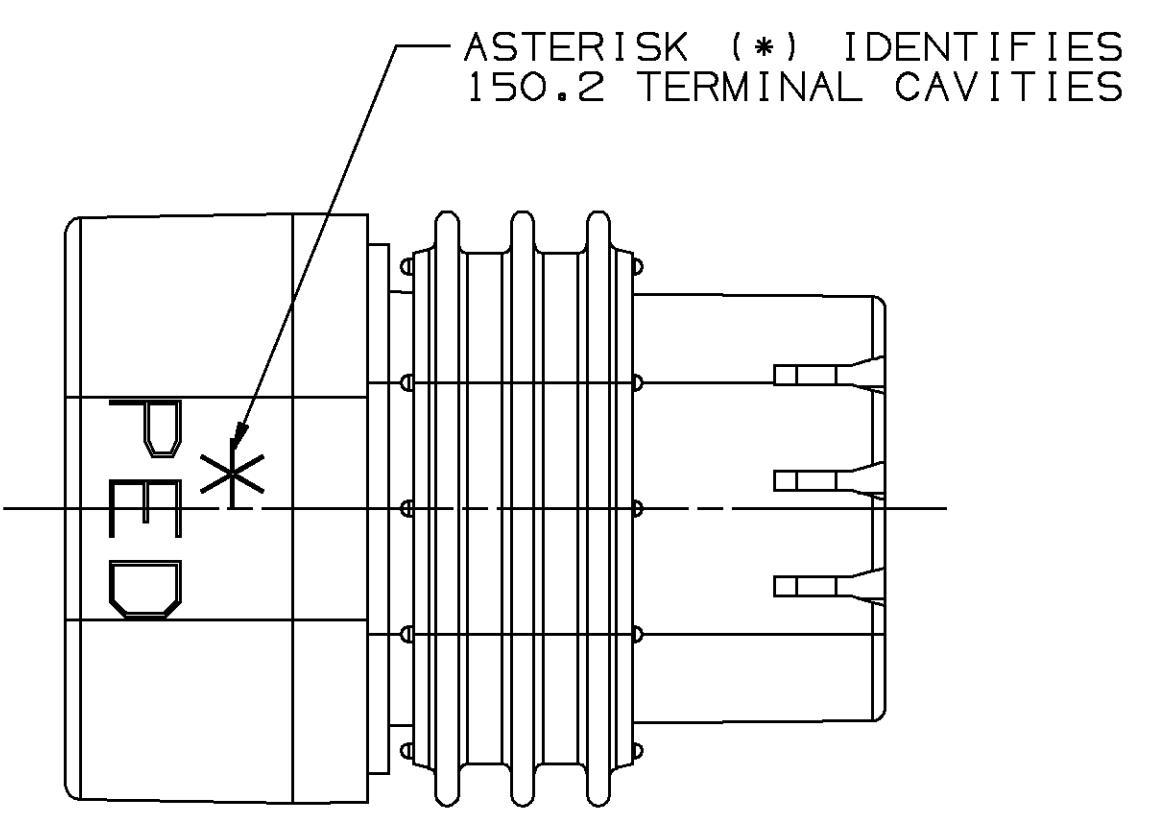

TYPE 101

P/N WITH ADHESIVE	REV	STATUS	P/N WITHOUT ADHESIVE	REV	STATUS	TYPE	CONNECTOR NO	CABLE SEAL NO	CONN SEAL NO	BLOCKED CAVITY
12186697	B		15339040	A		102	12162272	12092617	12047908	B
			12186831	A		102	12162272	12092862	12186824	NONE
			12162280	A		102	12162272	12047907	12047908	NONE
			12162279	A		102	12162272	12092862	12047908	NONE
			12162278	A		102	12162272	12092862	12110555	NONE
			12162186	A		101	12162181	12129090	12047908	NONE
			12162185	A		101	12162181	12092862	12047908	NONE
			12162184	A		101	12162181	12092617	12047908	B
			12162183	A		101	12162181	12059261	12047908	NONE
			12162182	A		101	12162181	12047907	12047908	NONE

- NOTES:
- CAVITIES TO ACCEPT 12124075 TERMINAL OR EQUIVALENT
 - FOR LEAD LENGTH CALCULATIONS DISTANCE FROM MATING END OF CONNECTOR TO FRONT OF CABLE CORE IS 8.60 ±1.55
 - WHEN PARTS ARE SHIPPED THEY MUST BE PACKED IN PLASTIC BAGS OR SHIPPING CONTAINERS MUST BE LINED WITH PLASTIC LINERS. BAGS OR LINERS MUST BE SEALED TO AVOID ENTRY OF FOREIGN MATTER
 - DIMENSIONS MARKED "REF" ARE FOR REFERENCE ONLY AND NO TOLERANCE LIMITS ARE ESTABLISHED
 - SEALING CODE 3
 DESIGN WILL PASS SALT FOG AND IMMERSION TEST AFTER CONDITIONING AS SPECIFIED IN ESA-644 (WEATHER-PACK), ESA-710 (METRI-PACK), ESA-650 (UNDERHOOD MICRO-PACK), C-4006 (WORLD CONNECTOR), ETC. - WHEN MATED TO MATING PART OR EQUIVALENT
 - FOR PART NUMBERS WITH ADHESIVE, USE PM003510 OR ADHESIVE APPROVED BY MATERIALS ENGINEERING TO GLUE CONNECTOR SEAL TO CONNECTOR
 - UNLESS OTHERWISE SPECIFIED AND/OR INDICATED: DIMENSIONS ARE TO FACE OF VIEW SHOWN AND AUTOMATICALLY ROUNDED BY COMPUTER FOR INSPECTION. (SEE MATH MODEL FOR PRECISE DIMENSION) FOR ALL OTHER DIMENSIONS NOT SHOWN BUT REQUIRED FOR TOOL BUILD, SEE MATH MODEL FOR PRECISE TOOL PATH DATA.

PART NO
1216 2266

DRAWING TYPE: **DETAIL/CPAD/PID**

OTHER DRAWINGS AVAILABLE: **METRIC**

THIRD ANGLE PROJECTION

CODE NO: 6900 GC: -C-5110 DES R: PINA 27JA94

DWG DATE: 27JA94 DR R: PINA 27JA94

SCALE: 4:1 CK T: MUDREY 08FE94

REFERENCE NO: APPR S.J. VUKMER 16FE94

MATERIAL SPEC: SEE CHART

NAME: ASM CONN F/M/P 150.2 P25

PART NUMBER: **1216 2266** SIZE: A0