



**AMP★ INSERTION TOOLS  
WITH BASE PART NUMBER 552714**

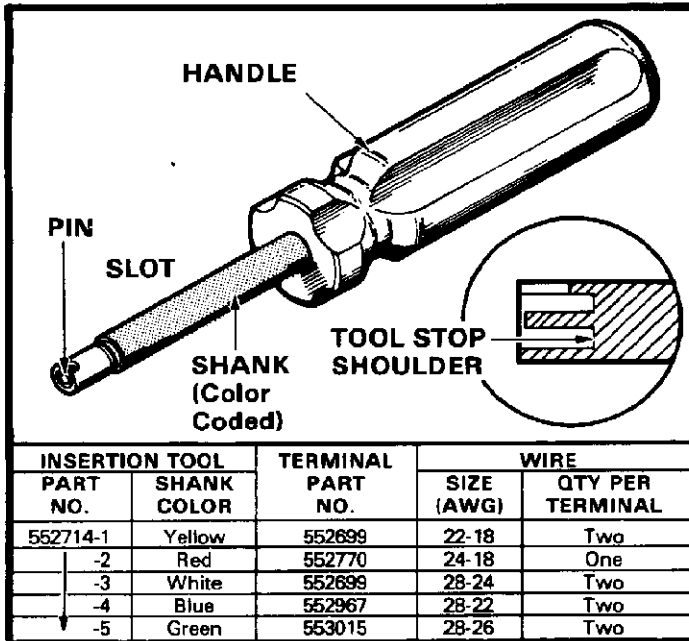
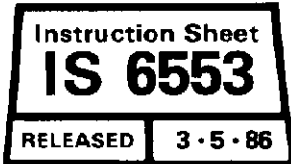

Fig. 1

**1. INTRODUCTION**

The AMP insertion tools listed in Figure 1 are designed to insert one or two unstripped wires into AMP-BARREL★ terminals that have previously been installed in a printed circuit board.

Refer to AMP Instruction Sheet IS 6505 packaged with the AMP-BARREL Terminal Insertion Kit 230549 for terminal insertion procedures. Read this material thoroughly before inserting any wires.

**NOTE** All dimensions presented on this sheet are in inches.

**2. DESCRIPTION (Figure 1)**

Each tool features a plastic handle and a color-coded heat-shrink tubing over a steel shank. The color-coded shank identifies the applicable wire size, wire quantity, and terminal part number for the tool. The tool shank has a slot on the tip and a pin inside the slot for pushing the wire into the terminal. A tool stop shoulder, inside the tool shank, prevents overinsertion of the wire in the terminal.

**3. INSERTION PROCEDURE**

Refer to Figure 1 and select the appropriate tool according to the terminal part number and the wire size to be inserted.

Refer to Figure 2 and proceed as follows:

1. Place wire over terminal slot with end of wire flush with back inside wall of terminal.

2. Position tool on terminal so that wire enters slot in tool shank.
3. Press straight down on tool handle until tool stop bottoms on terminal. Remove tool from terminal.
4. For two-wire application, repeat Steps 1 through 3. Second wire will push first wire down below the C-shaped cross-slot.

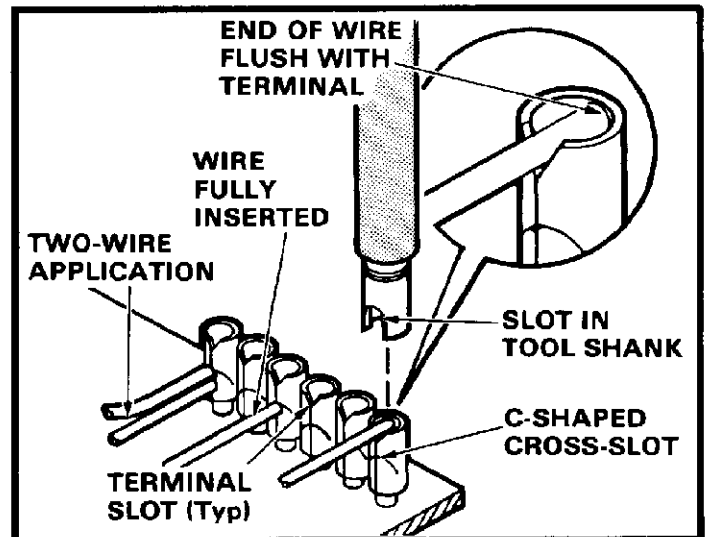

Fig. 2

**4. TOOL CERTIFICATION**

AMP insertion tools with base part number 552714 should be certified with the information provided in Figure 3. The tool should be inspected immediately upon arrival at your facility to be sure it has not been damaged in transit, and at regularly scheduled intervals to be sure it remains functional.

Additional tools can be purchased from:

AMP Incorporated  
P.O. Box 3608  
Harrisburg, Pennsylvania 17105-3608

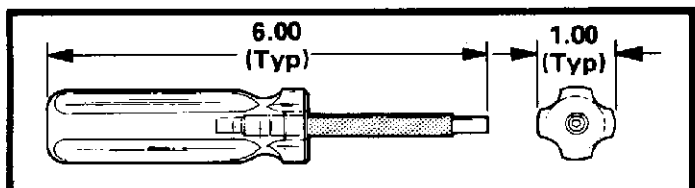

Fig. 3

INSERTION TOOL	PROD DESIGNED FOR AMP-BARREL TERMINAL	WIRE SIZE	ENGINEERING APPROVAL	DATE
552714-1	552699	22-18	<i>Paul D. [Signature]</i>	3/5/86
-2	552770	24-18		
-3	552699	28-24		
-4	552967	28-22		
-5	553015	28-26		

\*Trademark of AMP Incorporated

Copyright 1980, 1986 by AMP Incorporated, Harrisburg, PA. All International Rights Reserved. AMP Incorporated products covered by U.S. and Foreign patents and/or patents pending.